

# Entering Through the Closet

## SEANTII

Pratt Institute

Wentworth Institute of Technology

**Keywords:** Transgender, Sexuality, Identity, Gender, Power

**Architecture has made the socially normative body the primary audience for cities with a growingly diverse population. With this population evolving into one with an expansive idea of gender, the needs of our cities are beginning to challenge the historically rigid functions of space and spatial performance. Entering Through the Closet is a design manifesto exploring the future of trans-embodiment that extends beyond the body of the trans-gendered or the discourse of gender and gender non-conformists, and into that of architecture. Due to the constraints of economics and accessibility, the affordability of space becomes like that of the body given to one at birth, an assignment. Both the form of the domestic home and the form of the body hold identities that apply various restrictions and privileges to the self, occupying. The trans approach to the body is one challenging these restrictions through a deconstruction of the physical self. Entering Through the Closet identifies an architectural potential, methodology, and way of thought that requires one to deconstruct the historic identity of the old to provide habitability for the new, reconstructing architecture and architectural thought as we do ourselves**

## BUILT TO FAIL

The classification of human subjects into high/low-class, man/woman, queer/straight, white/non-white, cis/non-binary/trans shape the very definitions of what it means to be modern in today's society. With architecture both metaphorically and literally constructing modern ideologies, each of these categories are an inescapable part of the design process. Trans-embodiment has a large range of interpretation that varies upon region, upbringing, and personal relationship between mind and body. Here "transing" is defined as a cycle of questioning and adapting new ways of inhabiting one's body that can be applied to all discourses, especially architecture. Transing is a means of embracing new ways of thought that cannot be provided but only strictly discovered. Transing also has an inherent physicality to it, an evolution from the inside out versus a decoration or application. These physical changes hold a timeless permanency that battles what came before with what may come next. If architects look to the wear and tear of buildings as a narrative to find value

when creating future developments, then architecture will have a stronger connection with surrounding histories and contexts. Modernism holds fixed notions of how to inhabit in a body or how to inhabit a home, a transing approach to the body or space is an inherent act of revolution that carries a threat to these comforts. Architecture, the container in which societal standards, hierarchies, and values are performed and challenged, becomes a responsive and engaged symbol of both the political and social evolutions within our society.

Trans-embodiment extends beyond the mere rejection or alteration of one's gender or sex assignment at birth and into questioning, altering, or adapting the body one inhabits—a making or unmaking of the physical home. This approach harbors various forms of architectural undertones and creativity. In the essay *Breaking Ground on a Theory of Transgender Architecture*, Lucas Crawford points out that it is within these ways of thinking about our genders/bodies that we see how informed these bodily conventions are by architectural ideals, specifically the idea that "the home" is a good metaphor for the body at all.<sup>1</sup> The architectural narrative we give to ourselves requires then an architectural approach to our own emotional or physical transitions, however big or small. In this way, clothing is a decoration of the self whereas body-affirming surgeries or hormonal therapies act as a re-construction. In many ways, Crawford argues, it is the urgent need that transgender people have to find new ways of conceiving our bodies that offers a crucial shift in how we design, and also how we find a sense of ownership in our homes or communities.

Social culture, for better or for worse, is an inherent part of our survival. We value belonging, and the more we belong to the place we inhabit, whether in relation to people or structures, the more we are guaranteed a form of safety. Bell Hooks, an American author and social activist, describes our past and present localities as aspects of our identity that influence the ways we show up to our conversations, lives, and work. "I work towards changing the way I speak and write, to incorporate in the manner of telling a sense of place, of not just who I am in the present but where I am coming from...I refer to (those) personal struggle(s) to name that location from which I (came) to voice."<sup>2</sup>

Our construction of gender has recruited qualities such as value, rationality, purity, wealth, and ornamentation and bound them tightly to human identity creating associations of particular bodies with certain actions. Architecture has aided in achieving such qualities by targeting and associating design with certain consumer demographics. The advertisement of architecture as a representation of lifestyle, culture, and opportunity also utilized architecture to trigger, indulge, and curate fantasy. Playboy iconically promoted their House for the Bachelor as a space with an overt program for sexual power, with the architecture intending to act as projections of desire and dominance. The space was directly advertised to “the bachelor,” defined as a single man with “delicacy.” Playboy, in their design and advertising of the space, espoused the virtue of “playing the field” curating every switch, material, and surface around hosting, observation, and control. In the original advertisement of the home in 1956, the high handsome haven for the bachelor in town sells its design to someone looking for more than just a place to hang their hat. The narrative of the home and lifestyle it may offer describes the architecture as both a physical and psychological tool to win the admiration of his fellow men, but as well the desire of any woman.

“...The hanging Knoll cabinets beneath the windows holds a built-in bar. This permits the canny bachelor to remain in the room while mixing a cool one for his intended quarry. No chance of missing the proper psychological moment - no chance of leaving her cozily curled up on the couch with her shoes off and returning to find her mind changed, purse in hand, and the young lady ready to go home, damn it... The same advance thinking prompted the placement of an off-widget for the phone within the cabinet. No chance of a chatty call from the date of the night before shattering the spell being woven. (Don't worry about missing out on any fun this way: there's a phone-messenger-taker hooked to the tape recorder).”<sup>3</sup>

The importance of this passage is that it illustrates the pride and intent that corporations such as Playboy have to guide and influence our culture (specifically white, straight men) to utilize architecture as an aid in the success of coercive behaviors to manipulate and gain social capital, sex, or influence. “(here) within the walls, you are, literally, an irresistible host.”<sup>4</sup> This is one of many episodes in architectural history that reflects an outspoken connection between architecture and gender within our culture. Playboy's Bachelor Pad not only points to the inherent knot between the two (gender performance and architecture), but shows how the societal binary of gender has weaponized architecture as a tool to perpetuate systems of control and violence over varying demographics.

As people move throughout places, each person experiences a diverse sense of pleasures and discomforts. Bell Hooks states “(In) moving, we confront the reality of choice and location... This choice is crucial. It shapes and determines our response

to existing cultural practices and our capacity to envision new, alternative, oppositional aesthetic acts.”<sup>5</sup> Where we find ourselves defining home, be it a region or structure, speaks to our placement within an overall political and social history, experience, and privilege.

Modern, brutalist, and structural expressionist styles all respond to the same ontological fears of thinking, being, and loss, as well as societal disorder, panic, and revolution. The functional solutions to these styles have created an aesthetic that defamiliarizes people with place as a tool to maintain order. The problem with modernist perspectives is not that functional design methodologies do not contain value, but rather the ideology to sterilize the culture of a city through architectural formalism is, when interrogated, an active effort to erase the identities of those who are not seen as valuable by the architects leading this movement. Meaning, the visions of the architectural archetype (statistically a white, cis-gendered, able-bodied, heterosexual, man) remain at the forefront of architectural education and styles today.

Persevering through the death of leading voices such as Le Corbusier and Frank Lloyd Wright in the mid-late 1900s, the visions of their work remain monumented today regardless of their successes or failures. Eight properties of Wright ranging from homes, replicas, institutions, or museums, have been awarded the UNESCO World Heritage site designation. This designation is given to places on Earth that are of outstanding universal value to humanity and as such, have been inscribed on the World Heritage List to be protected for future generations to appreciate and enjoy. According to the United Nations Educational, Scientific and Cultural Organization (UNESCO), the “20th-Century architecture of Frank Lloyd Wright” has qualified under the guise of “Outstanding Universal Value.” Uniquely, the properties of Wright are not categorized separately as places of significance, but rather as a collective of eight designs by one architect. Nowhere else is a structure defined by its designer or lacks the historic background and depth as accompanying sites ranging from Yellowstone National Park to the Taj Mahal to the Great Wall of China. With their re-designation in 2019, it remains that the history, design, or significance of these properties is not being protected as much as their association with Frank Lloyd Wright. This recognition being the only example of a human identity on a World Heritage site designed to recognize properties and places of significance, demonstrates the power of influence figures such as Wright hold. There is no doubt that Wright's designs hold a significant place in history with the development of modern architecture, but the continued monumentation of his character over his work upholds our cultures approval of his repeated misogyny, racism,<sup>6</sup> and abuse.<sup>7</sup>

Similarly in vain, Le Corbusier remains a legend for his modern ideologies around framing, geometries, vision and direction. Known for his love of visuals he became addicted to the curation of what one saw. This led to his idyllic vision of culture and his plan for how architecture can aid in its becoming.

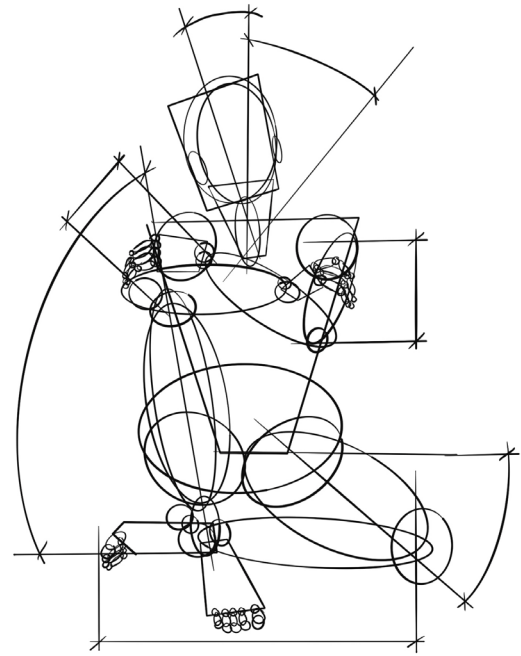
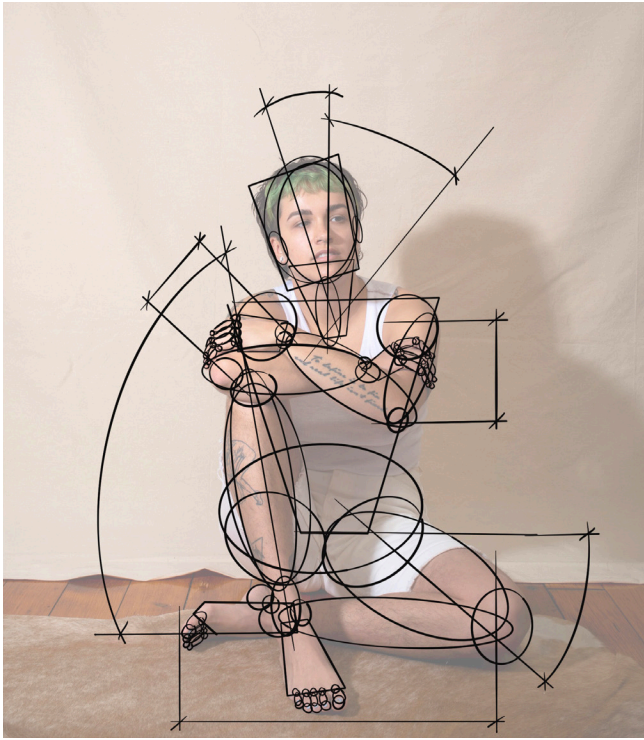

Figure 3 and 4 are a stylized diagram overlaying the photography of a non-binary body, taken by Melody Melamed, representing the immeasurable ways that bodies take up space. The relationship of bodies and space is a key element to the development of architecture. Unlike Corbusier's *The Modular*, the relationships between the two span a great distance beyond the limitations of formal measurements. When the typical figure and use of the body is transformed, so is its relationship with space. The lack of dimensionality in the figures speaks to the rejection of normative body standards and expectations. Each diagram extracted from each image is different, representing the inability of distilling a body into one essentialized representation. Photography by @melodymelamedfoto

“We strive for order, which can be achieved only by appealing to what is the fundamental basis on which our minds can work: geometry... Where the orthogonal is supreme, there we read the height of a civilization.”<sup>8</sup>

Le Corbusier's theories of scientific rationalism, efficiency, and social improvement through design are interwoven with rejections of diversity, inclusion, and difference in culture. This led to new approaches for city planning by the U.S. Housing Authorities to follow the guidance of modernist architects, like Le Corbusier, who strive for order and hierarchy over residents' unique needs or family and community structures. Le Corbusier proclaimed that the success of urban environments is order, and that order and reason were created through surrounding geometries, i.e. architecture. “Good or enlightened buildings (can) elicit similar attitudes or behaviors in individuals interacting with those buildings.”<sup>9</sup> His ideas for radiant cities disguised tactics such as racist displacement as designs featuring “garden areas on the outskirts of any primary design intervention for the eclectic man (to live or be placed).”<sup>10</sup>

As the contemporary city has grown, the restructuring of urban space continues to feed off of the fundamental principles of modernism and its pioneers: capitalism, cosmopolitanism,

and control. The effects of these principles are complex and paradoxical, as they both require a binary between the desired identity, or the “normal,” and the “other” in order to profit. As an abstract example: in order to sell soap a company must identify and sell the mess worth cleaning. However, the mess is required for the profit of the soap; to eliminate the mess completely would detract from the profitability of soap. When considering the “otherness” of identities like trans, queer, and nonbinary people within a social culture that profits from binary ideologies of gender and identity, queerness becomes part of the arsenal that governance uses to regulate sex, interaction, and sexualized spaces. Meaning: despite trans, queer, and nonbinary people being opposing identities of cultural “norms” a growing cultural acceptance of queerness in cities can be seen as a response to the profitability gained from having queer spaces, i.e. pride. Cities will promote, and possibly require, queer acceptance via flags and bright colors due to the sustained profit gained. Remarkably, as cities begin to be draped in rainbow flags and their streets filled with night life, the presence of queer-identified people dwindles as queerness is not born from capital, but the lack of it. This political connection makes the battle for change more complex than a simple redesign of space. Economics, privilege, and safety continue to be major factors in the creation and sustainability of authentically queer spaces.



Photograph: Cassady, Julian. Courtesy Nowadays, Julian Cassady Photography LTD. Mister Sunday. "The Mister Sunday Guide" **Time Out Magazine**, August 20, 2021.

### LIVING IN MARGINS

Queer "success" can be seen as an ability to survive and thrive beyond all limitations presented by cultural desire and profits. Authentically queer architecture becomes desirable when it does not meet the needs for normative profits and standards; the less desirable it is for the generalized public, the safer it tends to be for queer communities. It thrives in the ruin of normativity with some of the most iconic nightclubs taking place in the basements of abandoned buildings (intentionally left unnamed to aid in the necessity of its shadow). A popularized (and therefore safe) example to expose is Nowadays, a music and dancing venue in Brooklyn, New York. It welcomes artists and community into its space with established guidelines and policy procedures including a no-phone or photo policy on the dance floor and a strict zero tolerance policy for violence, racism, transphobia, sexism, or other discriminatory language. They also promote a strict "do not stare at anyone" rule and encourage guests to reach out to employees if they are made to feel uncomfortable at any point. This space has become a beacon to various minority groups in the community as well as becoming simply a safe place for anyone to go, dance, and be free. The design and organization of the venue holds an anarchist approach as it lies hidden behind the hand-made walls of fencing and metal panels to shield any views in from the street. The temporality of queer space is exemplified here as over the years of successful advertisement of this once-oasis has now been exposed by social-media influencers on platforms such as TikTok. Now, the golden rule of privacy has been dishonored as anyone can see

the faces and identities of the crowds of dancers in the videos discovered by searching "Nowadays Brooklyn." With this new, bright light cast upon the venue, voyeuristic audiences arrive any day of the week to wander and explore the slew of unique gatherings or community events. In a lot of ways, queer spaces are NOT for everyone. Events for minority communities require a form of safety and security for the audience to feel free and powerful. When a venue's function shifts from a protection of these values to a profit from these values, the labor of this protection transfers back onto the audience and its organizers. Currently, the remaining successful events for trans and nonbinary people at this venue exist due to the organizers unique forms of advertising that targets and draws in a particular demographic while deterring others.

The praise of ideologies by people in power such as Wright and Le Corbusier ignores the tools and methodologies that minority identities build to create and evolve spaces for safety and community. It is through the analysis and interrogation of these tools and methods that we discover new ways to thrive and live in ruin. These unique practices and approaches to space, reclamation, and safety, are acutely tied to trans and nonbinary practices of the body, and gender performance. These non-normative practices compared to modernist practices result in a spectrum where the value and beauty of any one thing can fall. Queer liberation cannot exist within formalist, modern constructs. The symbiotic relationship between modernism and capitalism

deems anything threatening modernist ideologies as a direct threat to the profits of those in power. For example:

- Trans-gendered approaches to the body threaten cis-gendered comforts.
- Trans-gendered comforts and freedom threatens the profit gained from binary cultural expectations.
- Communal living is a threat to suburban nuclear home lifestyles.

The rejection of modernist structures by both queer communities and various racial demographics results in not only the exclusion of these marginalized voices from architectural critiques, but also the exclusion of diverse ways of living being considered in major profitable architectural designs. This leads to the conception of a city to reflect various forms of citizen displacement and acceptance.<sup>11</sup> Similar to Michel Foucault's panopticon, modernism is the machine in which everyone is caught, both those who are in power and those over whom it is exercised.<sup>12</sup> If non-normativity is a threat to modernism and profit, then those participating in (and profiting from) modernism are, in effect, actively rejecting non-normative ways of life.

Jean Paul Sartre, a French philosopher and key figure in the development of the philosophy of existentialism and phenomenology, defines this "monumenting" in his book *Being and Nothingness* as "...a way of modifying the shape of the world; arranging a means in view of an end."<sup>13</sup> He identifies a common act that we, as humans, do almost naturally and inherently with a bias. Looking at the world through a critical lens, the singular, individual mind analyzes the state of its environment in relation to the body's personal comfort. To Sartre, as one searches to modify their conditions, whether physical or situational, they do so in hopes of achieving improvement. The trans search for survival is rooted in a search for habitation. Each modification is a response to personal need in relation to one's environment.

Like conjoined twins, bodies and buildings are so fused that any attempt to detach one from the other would, in a sense, kill both.<sup>14</sup> There is a type of lesson offered by trans-bodies through their physicality and solidity. Lucas Crawford defines this in his book *"Transgender Architectonics,"* as a type of body committed to an "ethos of change."<sup>15</sup> Although trans and gender non-conforming bodies represent both a particular challenge and response to normative standards, all bodies grapple with a version of building and unbuilding themselves in response to their environments.

Philippe d'Anjou elaborates on this definition by contextualizing it within the mind of a designer. Architectural and urban designers envision a desired reality by identifying and fulfilling what they see as a lack in the built environment. For a designer to act on this development or vision presupposes the conception of what is not, what can become, and what should be reality.<sup>16</sup>

However, no "factual" state exists to declare this as truth or a societal norm. The intent itself is actually being derived from a human bias of the designer. As Sartre says, "this act is a projection of a singular person's consciousness."<sup>17</sup>

### ENTERING THROUGH THE CLOSET

The trans-embodied approach to rebuilding either the body or space has two inherent key factors. First, trans-embodiment not only extends beyond oneself and onto the other ("other" meaning other bodies or surroundings), but it also requires a constant dialogue. This proposes a continuous shifting, improvisation, and reaction against the rigidity of binary lifestyles and expectations of performance and look. Bodies that require being split open, reorganized, removed from, and added to all reject the binary notions of right and wrong. Instead, they embrace fragmentation, irregular surfacing, and scarring as a form of function and habitation. How can we turn away from the fixed notions of habitability and formalism within architectural practices? Can we look at irregular building forms as adaptable, structural or interior prosthetics as beautiful, and abstract removals of unnecessary spaces as a memorialization to what aided in our becoming?

Secondly, trans-embodiment is not a design solution, but a methodology of how to approach, observe, and build upon space. Meaning, contrary to popular belief, there is no finite destination or style for trans or gender non-conforming bodies. This methodology, using evolution as a tool, proposes a destination to which many transgender people are indifferent.<sup>18</sup> Due to the heterogeneous nature of the trans identity and experience, no one pursuing body-altering or body-manipulative measures can depend on a concrete outcome. Similarly, all bodies age, heal, and wear differently. The revolutionary quality of trans-embodiment is the embracing of our inherent human entropy. As Jack Halberstam states in his essay on *Unbuilding Gender*, "In an enormous paradigm shift, we have begun to think less about definitive transition and more about a continuous building and unbuilding of the body (needs and environment)."<sup>19</sup>

If the architectural body has structural bones, a facade as skin, and a use in dialogue with that which surrounds it, then architecture, like the human body, has a lived and evolving experience. The commonalities between the two suggest that many lessons about the human body can be taken and applied to the architectural body and vice versa. Architecture is fundamental to our survival and our ecology. In order to see how the life of a building aligns with human survival, consider the analogy of the body as home. The body must consider and respond to its surrounding weather conditions, it requires protection and maintenance, it ages, it is engaged with, and every day must have an adjusted approach to survival, even by a single degree. This methodology requires a collective approach, and argues that individualism is the greatest threat to trans/inclusive/adaptable design as well. Alok Menon—a writer, artist, and performer, who explores trauma, belonging, and the human condition—describes the

history of the individual as a ghost story. They remind us all that this history of seeing ourselves as severed from one another (from an ecology) was implemented through various violent conquests and subjugations of minoritized people.<sup>20</sup> We forget that the superimposition of the Western psyche affects how we perceive the world around us and our relation to it. Alok goes on to describe separation itself as a fictional story, how even with a pandemic there was a surprise that we all breathe the same air... "It is impossible to have a self that's not in relation."<sup>21</sup> In the search to fully understand ourselves in space with community, we require an understanding of our relationships with architecture. The more we tune into what designs have or have not worked and are honest about what creates safety or harm, not only are we able to unlock a more sustainable path forward, but we shine a light on the narratives overlooked by harmful design strategies in the past.

We can shift our modes of perception and be curious about what we've been taught in order to revolutionize what we believe to be real, valid, or successful. The separation between two people, between man and woman, between user and home, or any other type of arbitrary category or distinction is the culprit of our fear or denial of the bigger whole. The power of trans-identities, and the hope for a trans-embodied architectural practice, is perseverance through change. There is no singular way to exist in a body (i.e. to be a man or a woman) and therefore one must undergo the work of finding who they are in relation to the world around them. In the same manner, a structure and its contextual relationships fluctuate through time. The multiplicity of layers within a novel's character arcs gives success to a story's depth. Comparably, we can be drawn to the layers of history on the facade of a building or the physical and emotional signs of growth we see in the people we meet. We may find ourselves connected to an authentic style of anything that embraces its history and represents not just itself as it is within a singular moment in time, but the journey it took to get there.

The concept of "Entering Through the Closet" challenges us to visualize architecturally the queer metaphor of becoming and the trans act of evolving. What would it mean to introduce a guest to our most vulnerable parts on their way into our home? If you couldn't or didn't need to hide yourself? If the dust, condoms, lingerie, masks, journals, tuxedos, sex toys, pornography, cigarettes, and playboys were all left out or put on display to act as the vestibule hall monumenting YOU to those entering? Would it change who you allowed in? Would we consider our spaces more sacred? Would we all become a little more honest or authentic? How can both the human and architectural body act, evolve, grow, and live symbiotically? If the thought of this design proposal frightens you, consider the way architecture, much like our bodies, is a tool we use to protect and yet expose truths: to carry art, to feel comfort, to fend off intruders, and invite those we love in.

## ENDNOTES

1. Crawford, Lucas Cassidy. "Breaking Ground on a Theory of Transgender Architecture." *Journal for Social Justice* 8, no. 2 (2010): 515–39.
2. Bell Hooks, "Choosing the Margin as a Space of Radical Openness," *Framework: The Journal of Cinema and Media*, no. 36 (1989): 15–23. <http://www.jstor.org/stable/44111660>.
3. Sanders, Joel, and Unknown. "Playboy's Penthouse Apartment." In **Stud: Architectures of Masculinity**, 61. New York, NY: Princeton Architectural Press, 1996.
4. George Wagner, et al. "The Lair of the Bachelor," **Architecture and Feminism**, (Princeton: Princeton Architectural Press, 1996), 196.
5. Hooks, 15.
6. Budds, Diana. "The Frank Lloyd Wright Project History Conveniently Forgot." *Fast Company*, July 11, 2017. <https://www.fastcompany.com/90132505/the-frank-lloyd-wright-project-history-conveniently-forgot>.
7. Friedland, Roger, and Harold Zellman. **The Fellowship: The Untold Story of Frank Lloyd Wright and the Taliesin Fellowship**. New York, NY: Harper Perennial, 2007.
8. Corbusier, Le. Story. **The City of To-Morrow and Its Planning**, translated by Frederick ETCELLS. Mineola, NY: Dover, 1987. 95.
9. Birmingham, Elizabeth. "Refraining the Ruins: Pruitt-Igoe, Structural Racism, and African American Rhetoric as a Space for Cultural Critique." *Western Journal of Communication* 63, no. 3 (1999): 296. <https://doi.org/10.1080/10570319909374643>.
10. Le Corbusier, Frederick Etchells, "A Contemporary City," **The City of Tomorrow and Its Planning**, (London: John Rucker, 1929), 21.
11. David Bell, Jon Binnie, "Authenticating Queer Space: Citizenship, Urbanism and Governance," *Urban Studies* 41, no. 9 (2004): 1080. <https://doi.org/10.1080/0042098042000243165>.
12. Michel Foucault, **Discipline and Punish: The Birth of the Prison**, (New York, NY: Vintage Books, 1977) 156.
13. Jean-Paul Sartre, "Being and Nothingness," **Being and Nothingness: A Phenomenological Ontology**, (New York, NY: Washington Square Press, 1972), 563.
14. Jack Halberstam, "Unbuilding Gender," *Places Journal*, (October, 2018). <https://doi.org/10.22269/181003>.
15. Lucas Crawford, "Introduction," **Transgender Architectonics the Shape of Change in Modernist Space**, (London: Routledge, 2020), 17.
16. Philippe d'Anjou, "Beyond Duty and Virtue in Design Ethics," *Design Issues* 26, no. 1 (2010): 97. <https://doi.org/10.1162/desi.2010.26.1.95>.
17. Sartre, 563.
18. Halberstam, 31.
19. Halberstam, 31.
20. ALOK Menon, Prentis Hemphill, "S3.E2. Continual Becoming with ALOK," *Finding Our Way Podcast*, (July 4, 2022). <https://www.findingourwaypodcast.com/individual-episodes/s3e2>
21. ALOK.